

**HAZ
METAL**

Your Fixing Systems Specialist



Anchor Bolts

Technical Product Catalogue

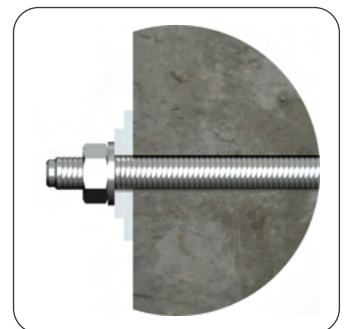
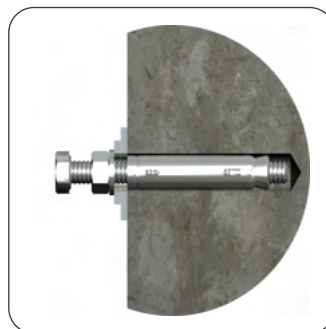
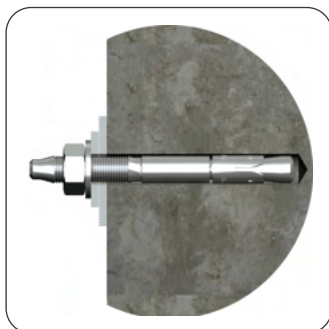



White Square Office Centre, Moscow

Contents

Introduction	1	HB09 HAZ Super - Technical Details	14
Anchor Bolts - Introduction	2	HB13 Wall Plug - Technical Details	15
Expansion Bolts - Technical Overview	3	HBB Blind Bolt - Technical Details	16
Anchor Bolts - Technical Overview	4	HSDS-4 Concrete Screw - Technical Details	17
HB01 Sleeve Bolt - Technical Details	5 - 6	Additional Bolts	18
HB03 Through Bolt - Technical Details	7 - 8	Anchor Bolts Edge Reduction Factors	19
HB05 Shell Bolt - Technical Details	9 - 10	Expansion Bolts Reduction Factors	20
HB06 Drop in Bolt - Technical Details	11	Chemical Bolt Reduction Factors	21
HB07 Chemical Bolt - Technical Details	12 - 13	Eurocode Concept	22

Introduction

Anchor Bolts

There are many types of expansion bolts available for use to fix anchors on to different types of walls. Expansion bolts are all tested to meet the pull out force and shear force performance criteria.

HB01
Sleeve Bolt



HB03
Through Bolt



HB05
Shell Bolt



HB06
Drop in Bolt



HB07
Chemical Anchor Bolt



HB09
HAZ Super Bolt



HB-WP
Wall Plug

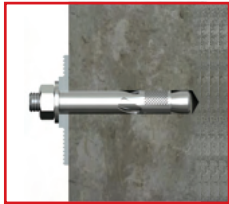

HB01 Sleeve Bolt

The HB01 Sleeve bolt is used for all types of fixings attached on to concrete walls or filled block work walls. The bolts are hammered into the drilled holes and the anchors are fixed by torquing the nut on the bolt. Good anchorage is achieved through the expansion of the sleeve through out the drilled hole.

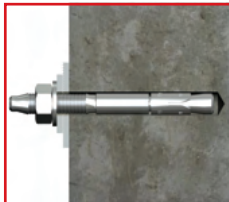

HB03 Through Bolt

The HB03 Through bolt is used for all types of fixings attached to concrete walls with a minimum C20/25 quality. The bolts are hammered into the drilled hole and fixing is done by torquing the nut. Final torque is achieved fast because the ring on the bolts is optimized to expand quickly. Safe fixture is made by the ring gripping firmly in the drilled hole.

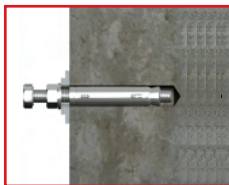

HB05 Shell Bolt

The HB05 shell bolt is used for fixings made on to concrete walls or filled and reinforced masonry walls. The shell is hammered into the concrete first until fully inserted. The torque is achieved using the hex bolt. As the torquing is made the shell is expanded firmly gripping the area around the drilled hole.

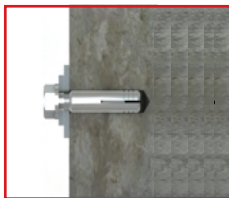

HB06 Drop in Bolt

The HB06 drop in bolt is used for fixing pipes, false ceilings etc. on to concrete walls. This bolt is installed in two stages. First the shell is hammered into the drilled hole with a hand tool, then the fixing is made with a hex bolt. Shells expands in the concrete hole as the pin opens the shell after setting process which firmly grips the area around the drill hole. Fixture is made by a hex bolt in to the shell which is anchored into the substrate.

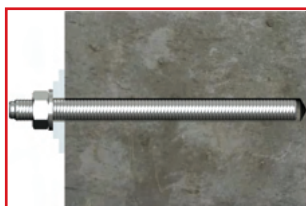

HB07 Chemical Bolt

The HB07 chemical bolt is used for fixing steel construction elements on to hollow block work and hollow masonry walls as well as concrete walls. Chemical capsules or epoxy acrylate tubes is inserted or injected in to the drilled holes and the bolts are set in to the holes. Anchors are fastened after the adhesive has cured.

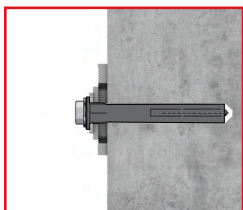

HB-WP Wall Plug

The HB-WP Wall Plug bolt is used for fixing anchors onto various type of walls. The bolts are set into the hole of the wall in combination with the plastic plug. The expansion of the plug in the drilled wall as the screw sets in creates a rigid connection on to the wall. This type of anchor bolts are used to install brackets for light weight rainscreen applications.



HB09 HAZ Super

The HB09 HAZ Super Bolt was designed to address specific needs in stone cladding applications where fixing from the rear side of the stone panel is required. When combined with an appropriate drilling technique, it provides a secure and effective anchoring solution. The HB09 HAZ Super Bolt is suitable for stone panels with thicknesses ranging from 20 mm to 50 mm.

Anchor Bolts - Introduction



A



B



C

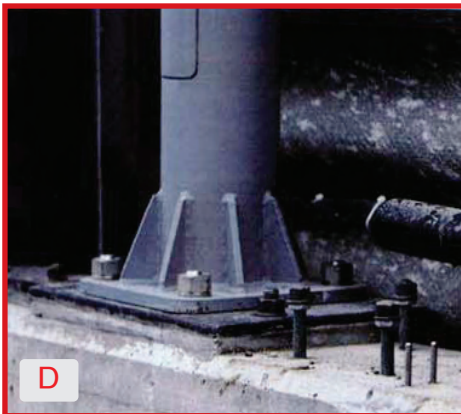

D

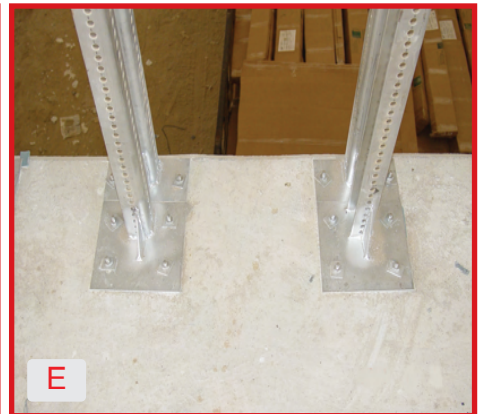

E

Expansion bolts are used through out construction for many connections made on to load bearing structures.

Some examples are shown on this page with explanations below:

A: Fixing of anchors on to filled block work walls using HB05 shell bolts.

B: Fixing of natural stone on to concrete walls with HB03 through bolts..

C: Fixing of channels with channel supports and channel restraints on to concrete wall with HB03 through bolts.

D: Fixing of steel post on concrete base floor with HB07 chemical bolts.

E: Fixing of steel substructure on to concrete floor using HB03 through bolts .

F: Fixing of brackets on to concrete beam using HB01 sleeve bolts.

G: Fixing of shelf racks on to concrete floor using HB03 through bolts.

H: Fixing of pipes on to concrete ceiling with HB06 drop in bolts.

I: Fixing of ladder on to concrete wall HB01 sleeve bolts.

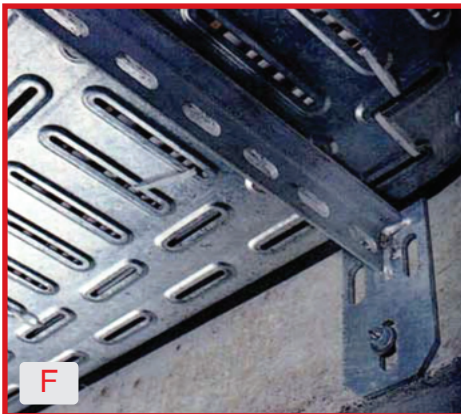

F



G

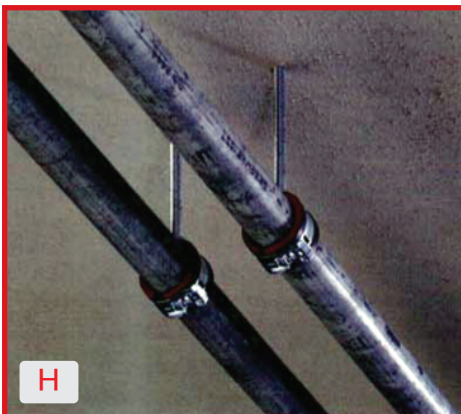

H



I

Expansion Bolts - Technical Overview

Installation:

To achieve optimum performance values it is essential that all bolts are installed correctly as shown on the installation instructions. Basic points are listed below:

- i) Drill correct diameter hole to the correct depth.
- ii) Clean hole thoroughly.
- iii) Use the correct setting sizes.
- iv) Tighten to the recommended torque using a torque wrench.
- v) Take into consideration the safe edge distances.
- vi) Use adequate washers to establish enough clamping force on the fixture.

Drilling: Drilling must be made using appropriate tools and diamond drills. The drill bits must correspond to the correct size of the required drilling diameter and embedment length of the bolts technical specifications. Drilling must be done correctly and not by wobbling or vibrating as the hole diameter must not be larger than the diameter size of the drill bit.

Cleaning of the hole: When holes on the load bearing walls are drilled with diamond drill bits, special care is required to clean the holes thoroughly. The holes must be brushed and blown out to leave the hole free from dust.

Setting the bolt correctly: When installing, the bolt must be set into the hole as depicted on the technical details as this will ensure the optimum performance of the bolt.

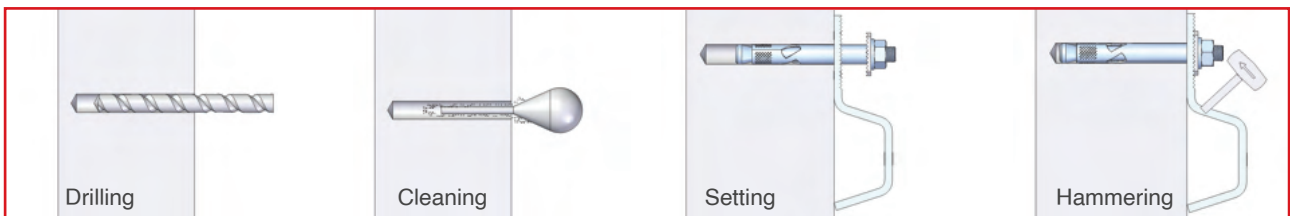

Torque sizes:

Torque controlled expansion exerts clamping force to the base material through the fixture. Clamping force is directly proportional to tightening torque. Tightening the bolt enables expansion to surround the hole 360 degrees to provide secure fixing. Tightening in accordance to the recommended torque sizes ensures a clamping force which is greater than the working loads. The tightening must not exceed the torque size as this will over stress the bolt and the base material which may result in bolt failure. Adjustable torque wrenches of the break back type are recommended for setting fixings.

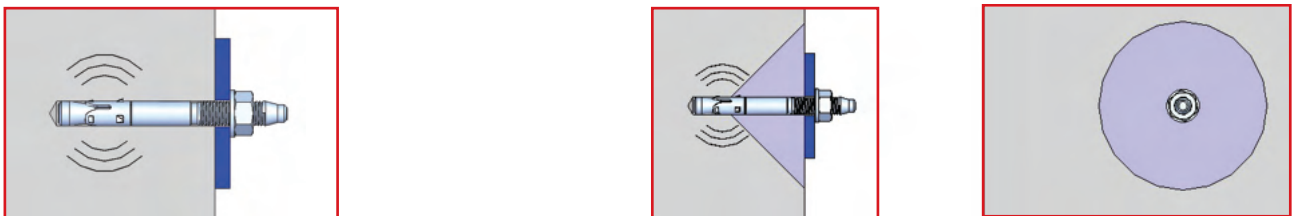

Safe edge and spacing distances:

Torque controlled bolts transmit expansion forces by locally compressing the base material. The forces are exerted at the point of expansion not over the whole length of the fixing. On applying the load to the bolt, additional forces are exerted around the concrete cone. It is this projected area which relates to the performance of the bolt. Thus this area must not be interfered with base material edge or another bolt fixing and its projected area. As the embedment depth increases the larger the cone and the greater the performance of the bolt. There must not be any interference with base material edge or another bolt fixing and its projected area as this will decrease bolt performance and may result in base material failure. Any reduction in the projected area will result in reduced performance and should be avoided if possible. Where unavoidable the appropriate reduction factors shown for reduced spacing or edge distance should be applied to the recommended load resistance indicated for the bolt.

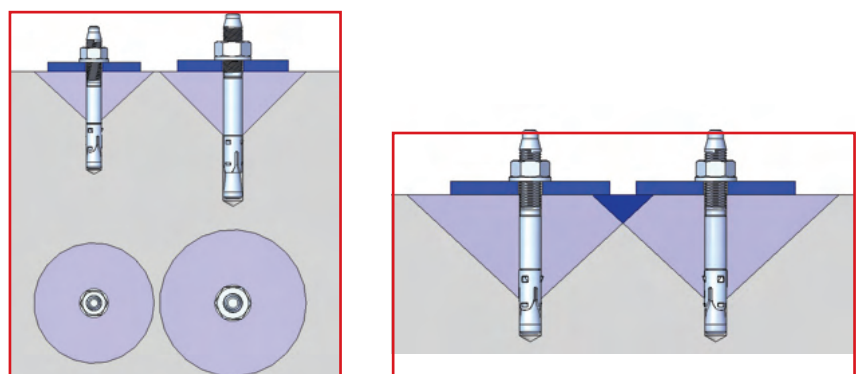

Use of serrated or oversized washers for slotted holes:

When fixing bolts through slotted holes it is important to ensure that there is adequate surface contact between the washer and the fixture to guarantee positive clamping force.

Anchor Bolts - Technical Overview

Base Material (Load bearing wall)

Types of base materials play an essential role when choosing the type of bolt to be used. Distinction is made between concrete, masonry and block work walls.

Concrete walls: Concrete is a base material that contains cement and gravel. The performance of expansion bolts on concrete walls depends on the compressive strength of the concrete. The most common concrete compressive strength is C20/25 which means that there is 25 N / mm² compressive strength on the concrete.

Brick walls: Brick walls are build with individual brick layer on top of each other and bonded together with mortar. Brick walls may be constructed with either hollow or solid bricks. The choice of bolts to be used largely depends on whether the bricks are hollow or solid.

Block work walls: Block work walls are build with individual blocks layer on top of each other and bonded together with mortar. Block work walls may be constructed with either hollow or solid blocks. The choice of bolts to be used largely depends on whether the blocks are hollow or solid.

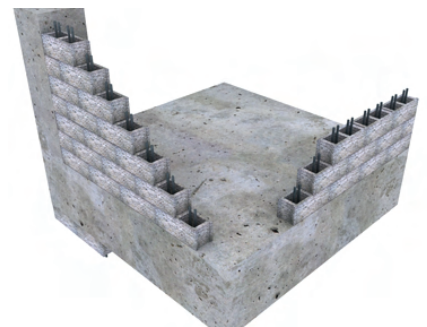
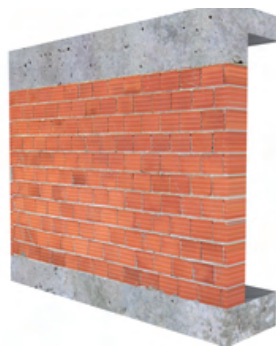

Load Direction

The direction of loads applied must be taken into consideration when an appropriate bolt is to be selected.

N Pull out loads criterion $N_{ed} \leq N_{rd}$: Pullout loads are applied along the axis of the fixing. Common examples are dead loads applied on ceiling applications or wind loads on bolts used to fix brackets on to vertical surfaces. Pull out resistance is influenced by the anchorage strength of the bolt within the drilled hole.

Shear loads criterion $V_{ed} \leq V_{rd}$: Shear loads are applied at right angles to the axis of a fixing and directly against the face of the load bearing structure. Shear performance is influenced by the shear strength of the bolt material and the compressive strength of the load bearing structure.

Combined loads criterion $\frac{N_{ed}}{N_{rd}} + \frac{V_{ed}}{V_{rd}} \leq 1.2$:

Combined loads are the combination of pullout and shear loads. If the angle of combined load is within 10 degrees of pure shear or pull out load, then the safe working load for that direction may be taken into consideration. Otherwise the applied combination load should be resolved into its pullout and shear load.

Offset loads criterion steel $\frac{M_{ed}}{M_{rd}} + \frac{V_{ed}}{V_{rd}} \leq 1.0$:

Offset loads are applied at right angles on the fixing axis but are offset from the surface. In this situation the deflection of the bolt due to bending needs to be considered as well as the shear capacity of the bolt.

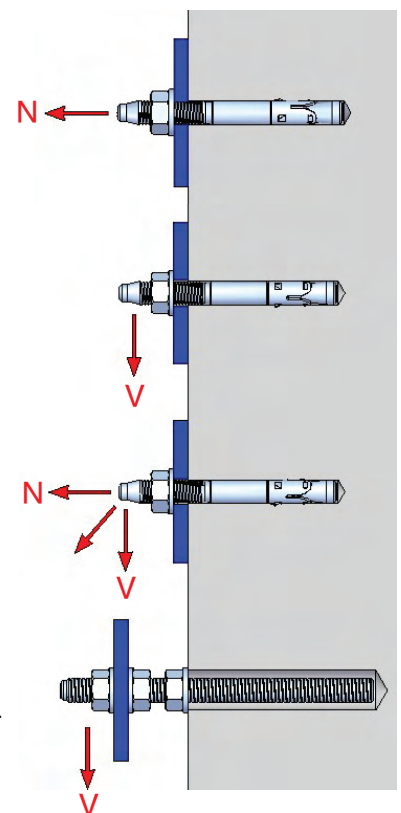

Failure Types

Bolting base failure

- High pull out and shear load.
- Low compressive base material.
- Low embedment length.

Disruption failure

- Incorrect base material dimensioning.
- Insufficient near edge spacing.
- High thermal expansion loads.

Bolt slip failure

- Incorrect installation or heavy load.
- Failure on bolt**
- Insufficient bolt resistance.

HB01 Sleeve Bolt - Technical Details

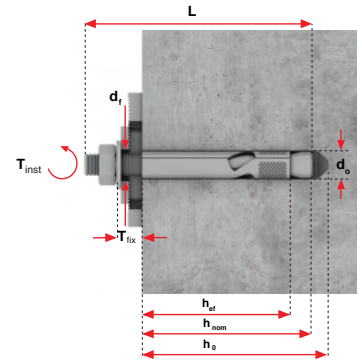

Product Code	Technical Details									
	Bolt Size	Embed. Depth	Maximum Fixture Thickness	Drilling Depth	Minimum Base Thickness	Thread Diameter	Drilling Diameter	Fixture Hole Diameter	Anchor Length	Max Torque
	(mm)	h_{nom} (mm)	t_{fix} (mm)	h_o (mm)	h_{min} (mm)	d (mm)	d_o (mm)	d_i (mm)	L (mm)	T_{inst} (Nm)
HB01-6/80	M6x80	40	10	65	100	6	8	9	80	10
HB01-8/80	M8x80	50	17	65	100	8	10	9	80	20
HB01-8/100	M8x100	50	37	80	100	8	10	9	100	20
HB01-10/80	M10x80	60	10	80	120	10	12	12	80	35
HB01-10/100	M10x100	60	20	80	120	10	12	12	110	35
HB01-12/100	M12x100	70	15	90	140	12	16	14	130	50
HB01-12/120	M12x120	70	35	90	140	12	16	14	145	50

Product Code Explanation:

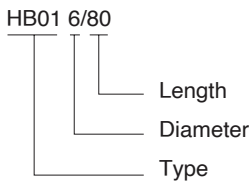

Anchor Bolt Mechanical Properties				
Product Size	M6	M8	M10	M12
<i>Threaded part</i>				
$f_{uk, threaded}$ (N/mm ²) Min. tensile strength	645	645	645	645
$f_{yk, threaded}$ (N/mm ²) Yield strength	500	500	500	500
$A_{S, threaded}$ (mm ²) Stressed cross section	31.2	36.6	58	84.3
W_{el} (mm ³) Section modulus	21	31	60	105
$M^0_{k,s}$ (Nm) Characteristic bending	10.4	21	42	75

Application:

- Concrete walls
- Filled hollow block walls
- Solid concrete dense block 7 N /mm

Available in:

- Stainless steel AISI 304 & AISI 316
- E.galvanized Mild Steel

Fixing Instructions

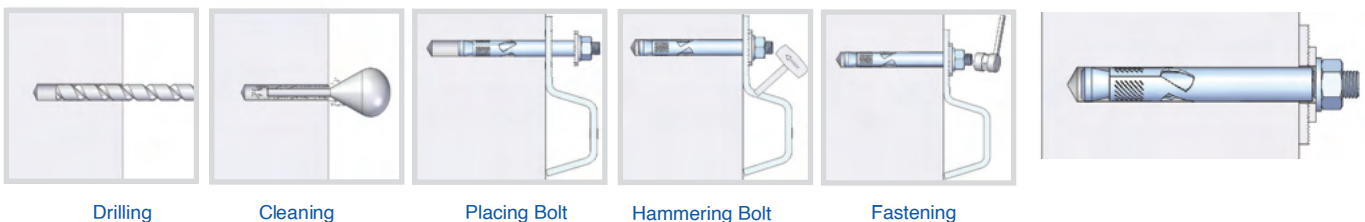

HB01 Sleeve Bolt - Technical Details

Loads and performance data

Product size			M6	M8	M10	M12	
Effective anchorage depth	h_{ef}	(mm)	45	50	70	84	
Characteristic loads, tension	$N_{Ru,m}$	(kN)	2	4	10	15	
Characteristic loads, shear	$V_{Ru,m}$	(kN)	7.5	12	20	57	
Non cracked concrete based values							
Recommended tensile loads	> C20/25	N_{Rec}	(kN)	1.2	2.05	4.65	6.95
	> C25/30	N_{Rec}	(kN)	1.36	2.35	4.95	7.4
	> C30/37	N_{Rec}	(kN)	1.72	2.60	5.35	8.2
	> C40/50	N_{Rec}	(kN)	2.05	3.1	6.4	9.2
	> C50/60	N_{Rec}	(kN)	2.4	3.7	6.95	9.7
Recommended shear loads	> C20/25	V_{Rec}	(kN)	5	6.2	12.40	16.25
Minimum spacing and edge distances for Concrete							
Effective anchorage depth	h_{ef}	(mm)	40	50	60	70	
Characteristic spacing	$S_{cr,N}$	(mm)	80	100	120	150	
Characteristic edge distance	$C_{cr,N}$	(mm)	65	80	80	120	
Minimum spacing and edge distance for concrete member - Concrete							
Thickness of concrete slab	h_{min1}	(mm)	80	100	120	150	
Minimum spacing	S_{min}	(mm)	40	50	60	70	
	For $C \geq$	(mm)	80	80	120	120	
Minimum edge distance	C_{min}	(mm)	50	60	80	80	
	For $S \geq$	(mm)	100	120	150	160	
Installation parameters							
Drill hole diameter	d_o	(mm)	6	8	10	12	
Drilling depth	h_o	(mm)	65	65	80	90	
Embedment length	h_{nom}	(mm)	47	50	60	70	
Maximum torque	T_{inst}	(N/m)	10	20	35	50	

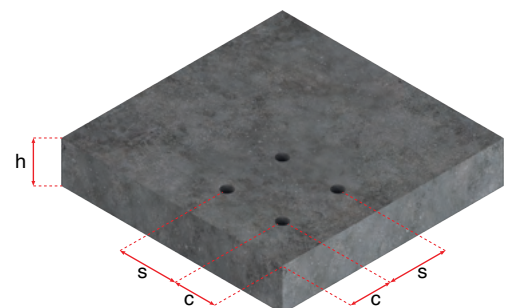
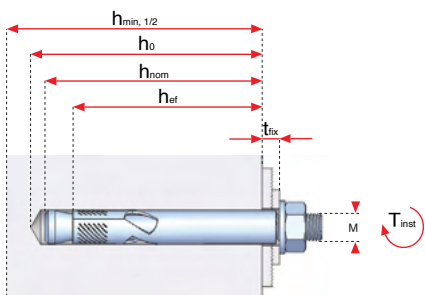

HB03 Through Bolt - Technical Details

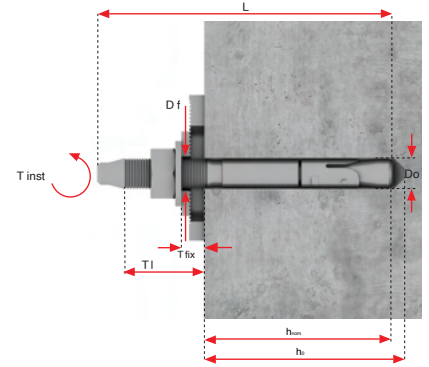

Product Code	Technical Details									
	Bolt Size	Embed. Depth	Maximum Fixture Thickness	Drilling Depth	Minimum Base Thickness	Thread Diameter	Drilling Diameter	Fixture Hole Diameter	Anchor Length	Max Torque
	(mm)	h_{nom} (mm)	t_{fix} (mm)	h_o (mm)	h_{min} (mm)	d (mm)	d_o (mm)	d_f (mm)	L (mm)	T_{inst} (Nm)
HB03-8/80	M8x80	50	17	65	100	8	8	9	80	20
HB03-8/100	M8x100	50	37	65	100	8	8	9	100	20
HB03-8/120	M8x120	50	57	65	100	8	8	9	120	20
HB03-10/90	M10x90	60	10	80	120	10	10	12	90	35
HB03-10/110	M10x110	60	30	80	120	10	10	12	110	35
HB03-10/130	M10x130	60	50	80	120	10	10	12	130	35
HB03-12/110	M12x110	70	15	90	140	12	12	14	110	50
HB03-12/135	M12x135	70	35	90	140	12	12	14	130	50
HB03-12/145	M12x145	70	50	95	140	12	12	14	145	50
HB03-16/130	M16x130	84	15	110	160	16	16	18	130	120
HB03-16/140	M16x140	84	25	110	160	16	16	18	140	120
HB03-16/165	M16x165	84	50	110	160	16	16	18	165	120

Product Code Explanation:

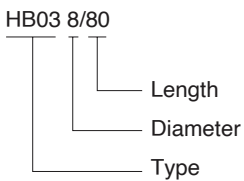

Anchor Bolt Mechanical Properties				
Product Size	M8	M10	M12	M16
<i>Threaded part</i>				
$f_{uk, threaded}$ (N/mm ²) Min. tensile strength	645	645	645	645
$f_{yk, threaded}$ (N/mm ²) Yield strength	500	500	500	500
$A_{S, threaded}$ (mm ²) Stressed cross section	36.6	58	84.3	157
W_{el} (mm ³) Section modulus	31.77	62.22	109.16	277.5
$M^0_{k,s}$ (Nm) Characteristic bending	21.8	43.5	76.4	194.2

Application:

- Concrete walls

Available in:

- Stainless steel AISI 304 & AISI 316
- E.galvanized Mild Steel

Fixing Instructions

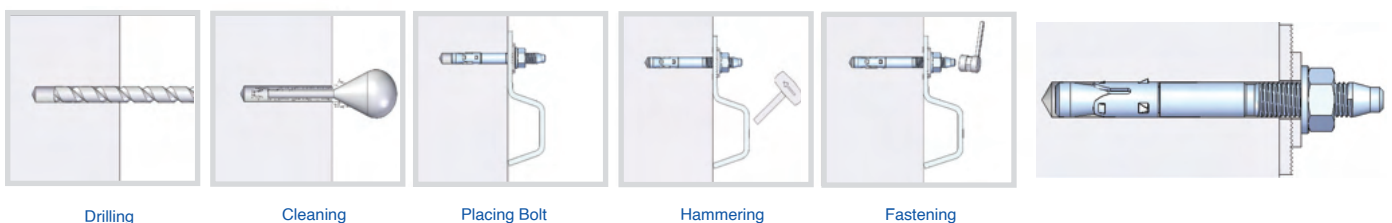

HB03 Through Bolt - Technical Details

Loads and performance data

Product size			M8	M10	M12	M16	
Effective anchorage depth	h_{ef}	(mm)	50	60	70	84	
Mean ultimate loads, tension	N_{Rk}	(kN)	4.5	12	16	24	
Mean ultimate loads, shear	V_{Rk}	(kN)	12.5	21.8	30.2	53.2	
Cracked concrete based values							
Recommended tensile loads	> C20/25	N_{Rec}	(kN)	2.14	5.71	7.62	11.43
	> C25/30	N_{Rec}	(kN)	2.40	6.28	8.53	12.57
	> C30/37	N_{Rec}	(kN)	2.61	6.97	9.29	13.94
	> C40/50	N_{Rec}	(kN)	3.02	8.05	10.74	16.11
	> C50/60	N_{Rec}	(kN)	3.32	8.85	12.03	17.71
Recommended shear loads	> C20/25	V_{Rec}	(kN)	7.14	12.45	17.25	33.26
Minimum spacing and edge distances for Concrete							
Effective anchorage depth	h_{ef}	(mm)	50	60	70	84	
Characteristic spacing	$S_{cr,N}$	(mm)	100	120	150	160	
Characteristic edge distance	$C_{cr,N}$	(mm)	80	80	120	120	
Minimum spacing and edge distance for concrete member - Concrete							
Thickness of concrete slab	h_{min1}	(mm)	100	120	140	160	
Minimum spacing	S_{min}	(mm)	40	50	60	70	
	For $C \geq$	(mm)	80	80	120	120	
Minimum edge distance	C_{min}	(mm)	50	60	80	80	
	For $S \geq$	(mm)	100	120	150	160	
Installation parameters							
Drill hole diameter	d_o	(mm)	8	10	12	16	
Drilling depth	h_o	(mm)	65	80	90	110	
Embedment length	h_{nom}	(mm)	50	60	70	84	
Maximum torque	T_{inst}	(N/m)	20	35	50	120	

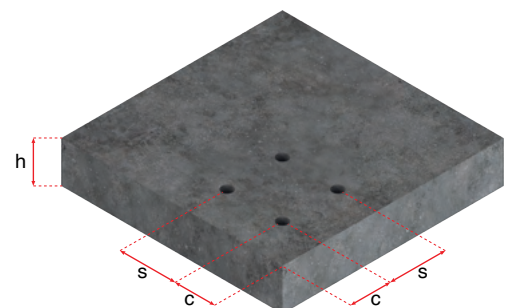
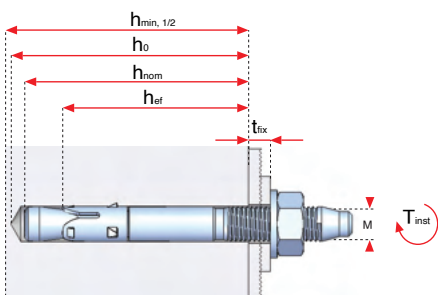

HB05 Shell Bolt - Technical Details

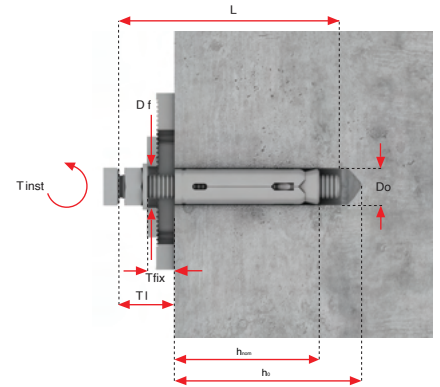

Product Code	Technical Details										
	Bolt Size	Sleeve Size	Embed. Depth	Maximum Fixture Thickness	Drilling Depth	Minimum Base Thickness	Thread Diameter	Drilling Diameter	Fixture Hole Diameter	Anchor Length	Max Torque
	(mm)	(mm)	h_{nom} (mm)	t_{fix} (mm)	h_0 (mm)	h_{min} (mm)	d (mm)	d_0 (mm)	d_1 (mm)	L (mm)	T_{inst} (Nm)
HB05-6/60	M6x60	10x39	43	10	65	150	6	10	7	60	10
HB05-6/80	M6x80	10x39	43	30	65	150	6	10	7	80	10
HB05-8/80	M8x80	12x44	47	25	70	200	8	12	9	80	20
HB05-8/100	M8x100	12x44	47	45	70	200	8	12	9	100	20
HB05-10/80	M10x80	15x50	57	10	85	250	10	15	12	80	40
HB05-10/100	M10x100	15x50	57	20	85	250	10	15	12	100	40
HB05-12/110	M12x110	18x64	64	25	100	300	12	18	14	110	75

Product Code Explanation:

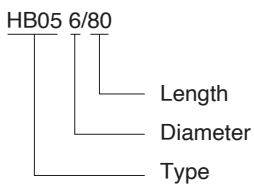

Anchor Bolt Mechanical Properties

Product Size	M6	M8	M10	M12
<i>Threaded part</i>				
$f_{uk, threaded}$ (N/mm ²) Min. tensile strength	700	700	700	700
$f_{yk, threaded}$ (N/mm ²) Yield strength	450	450	450	450
$A_{S, threaded}$ (mm ²) Stressed cross section	20.1	36.6	58	84.3
W_{el} (mm ³) Section modulus	12.72	62.22	109.16	277.5
$M_{k,s}^0$ (Nm) Characteristic bending	12	30	60	105

Application on:

- Concrete walls.
- Filled hollow block walls.
- Solid concrete dense block 7N /mm

Available in:

Stainless Steel AISI 304 & AISI 316 and
E.galvanized Mild Steel

Fixing Instructions

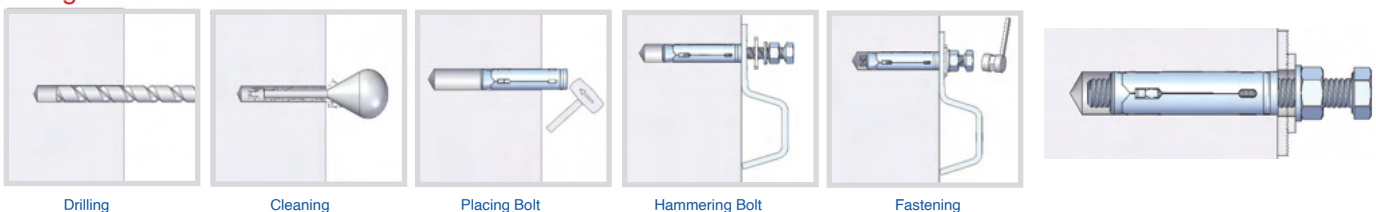

HB05 Shell Bolt - Technical Details

Loads and performance data

Product size			M6	M8	M10	M12
Effective anchorage depth	h_{ef}	(mm)	43	47	57	64
Mean ultimate loads, tension	$N_{Ru,m}$	(kN)	11	16	18	22
Mean ultimate loads, tension	$V_{Ru,m}$	(kN)	6.24	11.35	18	26.2
Recommended tensile loads						
> C20/25	N_{Rec}	(kN)	5.23	7.61	8.57	10.47
> C25/30	N_{Rec}	(kN)	5.86	8.52	9.60	11.73
> C30/37	N_{Rec}	(kN)	6.38	9.28	10.46	12.77
> C40/50	N_{Rec}	(kN)	7.37	10.73	12.08	14.76
> C50/60	N_{Rec}	(kN)	8.26	12.02	13.54	16.54
Recommended shear loads						
> C20/25	V_{Rec}	(kN)	3.56	6.48	10.29	14.97
Minimum spacing and edge distances for Concrete						
Effective anchorage depth	h_{ef}	(mm)	43	47	57	64
Characteristic spacing	$S_{cr,N}$	(mm)	110	130	210	220
Characteristic edge distance	$C_{cr,N}$	(mm)	65	72	105	110
Minimum spacing and edge distance for concrete member - Concrete						
Thickness of concrete slab	h_{min1}	(mm)	100	100	110	150
Minimum spacing for edge distance c	$S_{min/C}$	(mm)	80	90	110	160
Minimum spacing for edge distance s	$S_{min/S}$	(mm)	50	60	70	120
Installation parameters						
Drill hole diameter	d_o	(mm)	10	12	15	18
Drilling depth	h_o	(mm)	65	70	57	100
Embedment length	h_{nom}	(mm)	43	47	57	64
Maximum torque	T_{inst}	(N/m)	10	20	40	75

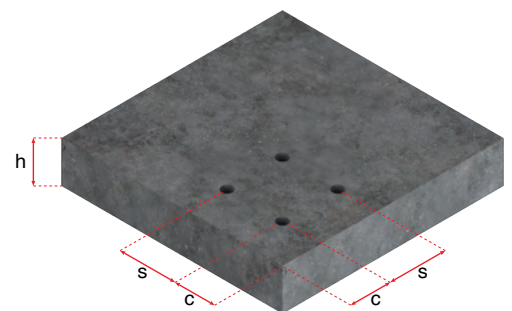
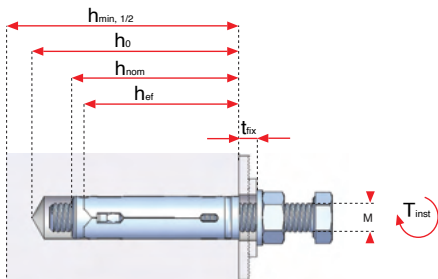

HB06 Drop in Bolt - Technical Details

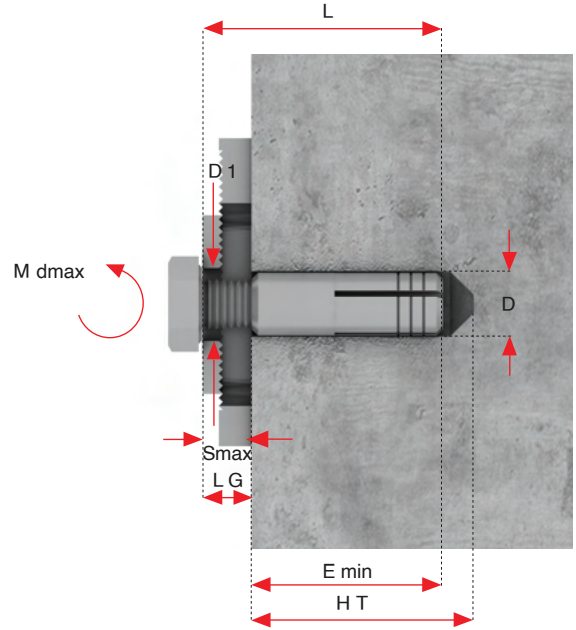

Product Code	Technical Details								
	Bolt Size	Shell Size	Drill Hole Diameter	Drill Length	Minimum Embedment	Maximum Fixture Thickness	Fixture Hole Diameter	Maximum Torque	Screw in Depth Min / Max
	(mm)	(mm)	D (mm)	H _i (mm)	E _{min} (mm)	S _{max} (mm)	D _i (mm)	M _{dmax} (Nm)	S _d (mm)
HB06-6	M6x20	Ø8x25	8	28	25	11	7	7	6/10
HB06-8	M8x25	Ø10x30	10	33	30	13	9	8	11/17
HB06-10	M10x30	Ø12x40	12	43	40	17	11	15	13/19
HB06-12	M12x35	Ø14x50	14	53	50	18	13	35	15/21

Product Code Explanation:

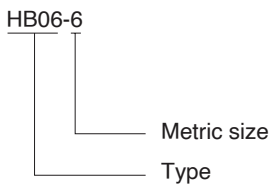

C25/30 strength class concrete base material values.

Allowable Loads (kN)					
Load direction	a derece	M6	M8	M10	M12
Pull out	0	2.00	3.20	4.35	6.00
Shear	90	1.78	3.30	3.90	6.80

A safety factor of 3.5 has been used against mean ultimate failure loads.

Application:

For fastening fixtures to concrete walls.

Available in:

Stainless Steel AISI 304 & AISI 316 and E.galvanized Mild Steel

Setting Tool:

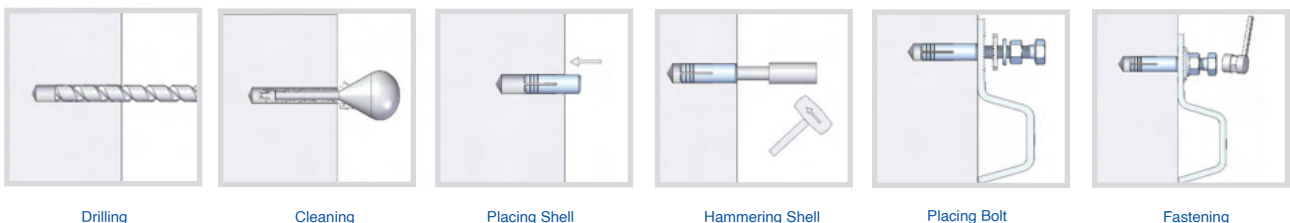
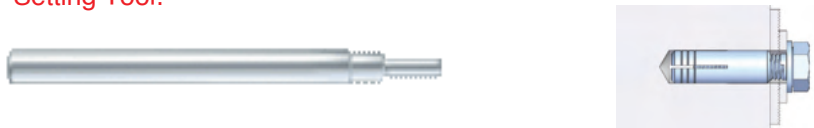

HB07 Chemical Bolt - Technical Details

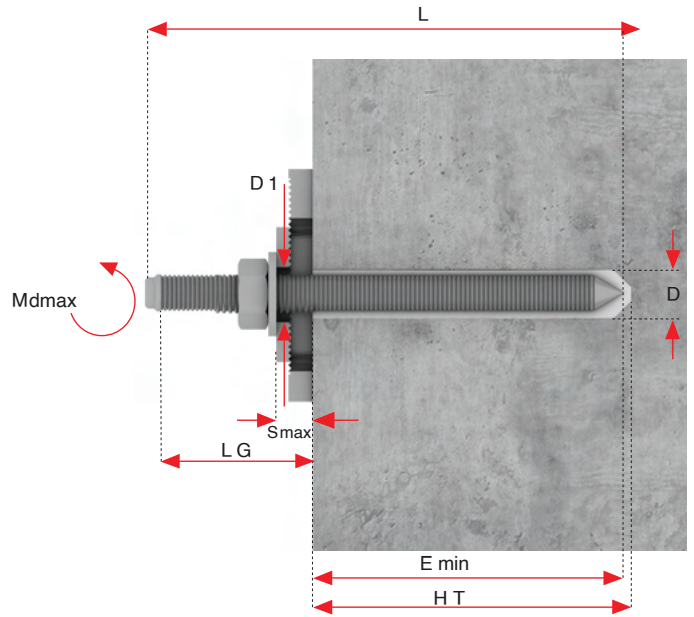

Product Code	Technical Details							
	Bolt Size	Drilling Depth	Minimum Embedment	Maximum Fixture Thickness	Fixture Hole Diameter	Maximum Torque	Bolt Length	Thread Length
	(mm)	H _i (mm)	E _{min} (mm)	S _{max} (mm)	D _i (mm)	M _{dmax} (Nm)	(mm)	S _c (mm)
HB07-8/110	M8x110	82	80	14	9	7	110	23
HB07-10/130	M10x130	92	90	21	11	15	130	30
HB07-10/170	M10x170	92	90	59	11	15	170	70
HB07-12/160	M12x160	115	110	28	13	25	160	40
HB07-12/190	M12x190	115	110	60	13	25	190	70
HB07-16/190	M16x190	130	125	38	17	60	190	52.5
HB07-16/260	M16x260	130	125	108	17	60	260	135

Product Code Explanation:

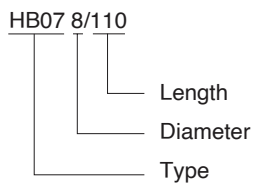

C20/25 strength class concrete base material values.

Load direction	Allowable Loads (kN)				
	a derece	M8	M10	M12	M16
Pull out	0	8,80	12,30	18,30	20,50
Shear	90	10,20	15,60	22,00	23,58

Application:

For fastening fixtures to concrete walls and filled block walls.

Available in:

Stainless Steel AISI 304 & AISI 316 and E.galvanized Mild Steel

Fixing Instructions

Injection gun



Epoxy acralyt capsule



Curing time & Temperatures

°C	cure
5	25'
10	15'
20	6'
30	4'
35	2'

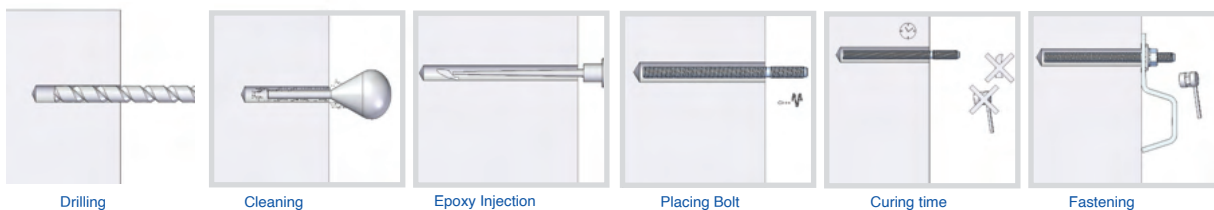

HB07 Chemical Bolt - Technical Details

Loads and performance data

Product size			M8	M10	M12	M16	
Effective anchorage depth	h_{ef}	(mm)	80	90	110	125	
Mean ultimate loads, tension	$N_{Ru,m}$	(kN)	8.8	12.3	18.3	20.5	
Mean ultimate loads, tension	$V_{Ru,m}$	(kN)	10.2	15.6	22	23.6	
Cracked concrete based values							
Recommended tensile loads	> C20/25	N_{Rec}	(kN)	4.4	6.2	9.2	10.3
	> C25/30	N_{Rec}	(kN)	4.9	6.9	10.3	11.5
	> C30/37	N_{Rec}	(kN)	5.4	7.6	11.2	12.6
	> C40/50	N_{Rec}	(kN)	6.2	8.7	13	14.5
	> C50/60	N_{Rec}	(kN)	7	9.8	14.5	16.3
Recommended shear loads	> C20/25	V_{Rec}	(kN)	5.8	8.9	12.6	13.5
Minimum spacing and edge distances for Concrete							
Effective anchorage depth	h_{ef}	(mm)	80	90	110	125	
Characteristic spacing	$S_{cr,N}$	(mm)	80	90	110	130	
Characteristic edge distance	$C_{cr,N}$	(mm)	120	140	170	190	
Minimum spacing and edge distance for concrete member - Concrete							
Thickness of concrete slab	h_{min1}	(mm)	100	120	140	160	
Minimum spacing	$S_{min/C}$	(mm)	40	50	60	70	
Minimum edge distance	$S_{min/S}$	(mm)	50	60	80	90	
Installation parameters							
Drill hole diameter	d_o	(mm)	10	12	14	18	
Drilling depth	h_o	(mm)	82	92	115	130	
Embedment length	h_{nom}	(mm)	80	90	110	125	
Maximum torque	T_{inst}	(N/m)	7	15	25	60	

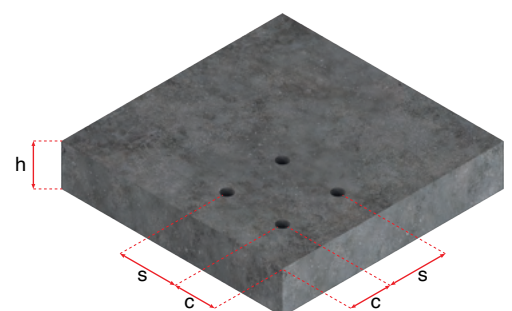
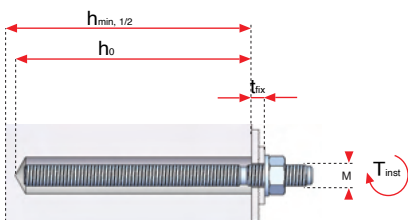

HB09 HAZ Super - Technical Details

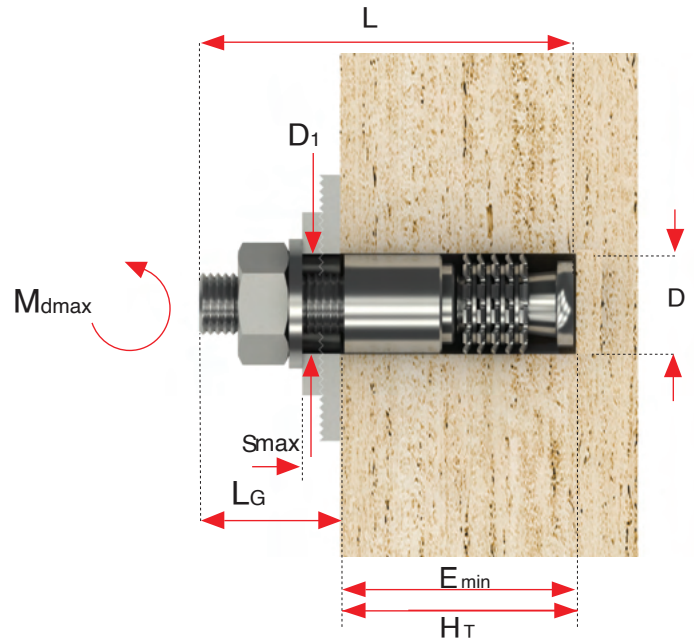

Product Code	Technical Details									
	Bolt Size	Stone Thickness	Drill Hole Diameter	Drill Length	Minimum Embedment	Maximum Fixture Thickness	Fixture Hole Diameter	Maximum Torque	Bolt Length	Thread Length
	(mm)	S _i (mm)	D (mm)	H _i (mm)	E _{min} (mm)	S _{max} (mm)	D _i (mm)	M _{dmax} (Nm)	(mm)	(mm)
HB09-24/30	M8x30	20	12	12	12	5	9	13	30	18
HB09-48/45	M8x45	30	12	22	22	5	9	13	45	23
HB09-72/60	M8x60	40	12	32	2	5	9	13	60	28

Product Code Explanation:

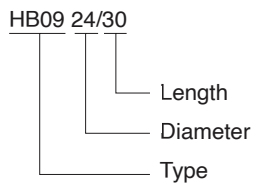

Application:

For fastening fixtures to natural stone

Available in:

Stainless Steel AISI 304 & AISI 316

Advantages of HB09 Haz Super Bolt

- No use of special and expensive drilling tools.
- No need of expensive drill bits.
- No stone breakage during fixation of bolt

Application examples:

Facade cladding

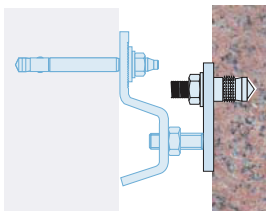

Corner Stone Fixing

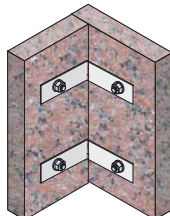

Vanity Top Fixing



Fixing Instructions

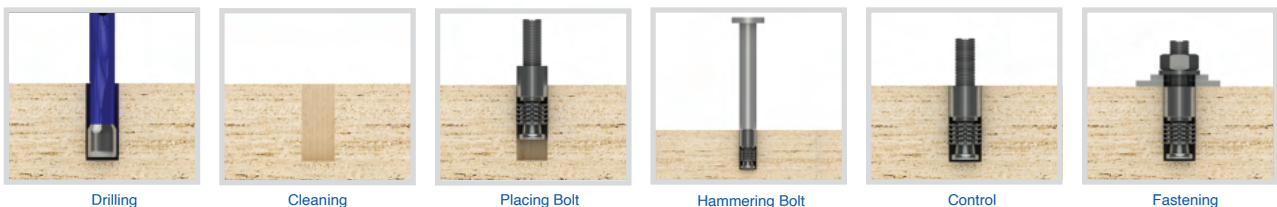

Hard Granite based values

Mean Ultimate (kN)		
Load direction	a degree	M8
Pull out	0	1,40
Shear	90	3,00

Marble based values

Working Load Resistance (kN)		
Load direction	a degree	M8
Pull out	0	1,00
Shear	90	2,10

A safety factor of 2.5 is taken for mean ultimate failure loads.

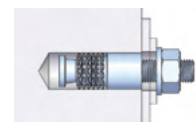

HB13 Wall Plug - Technical Details

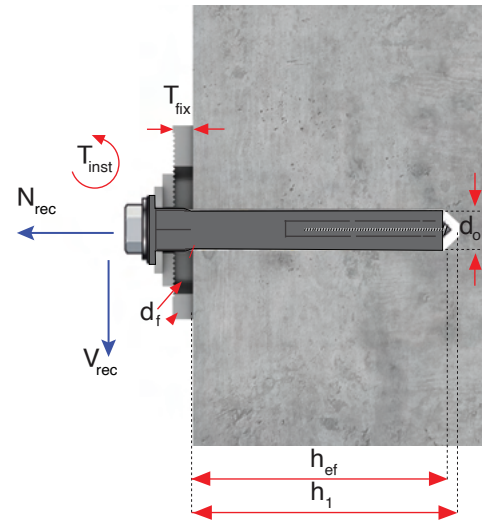

Product Code	Technical Details						
	Bolt Size	Drill Hole Diameter	Drill Length	Minimum Embedment	Maximum Fixture Thickness	Fixture Hole Diameter	Maximum Torque
	(mm)	D (mm)	H ₁ (mm)	E _{min} (mm)	S _{max} (mm)	D _f (mm)	M _{lmax} (Nm)
HB13-10/80	M10x80	10	100	80	10	10.5	15
HB13-10/100	M10x100	10	110	100	30	10.5	15
HB13-10/120	M10x120	10	120	110	50	10.5	15
HB13-10/140	M10x140	10	130	120	70	10.5	15

Product Code Explanation:

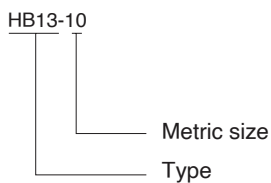

Admissible Loads	
<i>Compressive strength of aerated concrete [N/mm²]</i>	
Aerated concrete $f_b \geq 2$ N/mm ²	0.27 kN
Aerated concrete $f_b \geq 3$ N/mm ²	0.47 kN
Aerated concrete $f_b \geq 4$ N/mm ²	0.67 kN
Aerated concrete $f_b \geq 6$ N/mm ²	1.07 kN
<i>Characteristic Bending Moment</i>	
Steel screw ($\gamma_{Ms} = 1.5$)	11.80 Nm
Stainless steel screw ($\gamma_{Ms} = 1.187$)	11.02 Nm

Application:

For fastening fixtures to aerated concrete walls and block work walls

Available in:

Stainless Steel AISI 304 & AISI 316 and E.galvanized Mild Steel



HBB Blind Bolt - Technical Details

The BlindBolt is a blind fixing made from zinc flake-coated or stainless steel A4-70, designed for use in girder cavities or box sections. Its innovative design shortens installation time, and the variety of sizes allows for flexible selection based on fixture thickness.

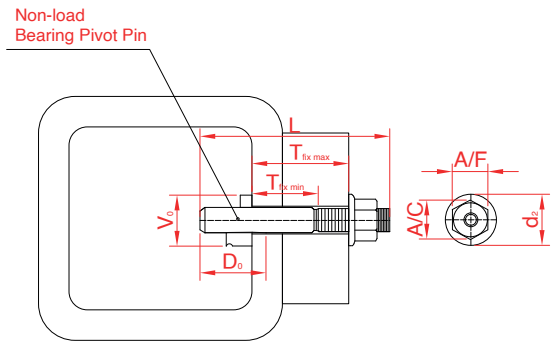

D_o: Depth Clearance
V_c: Anchor Clearance

Product Code	Physical Features										
	Size	Length	Hole Diameter	Fixture Thickness		Anchor Clearance	Depth Clearance	Minimum Hole Centres	Width Across Flats	Width Across Corners	Washer Diameter
				Minimum	Maximum						
(mm)	L (mm)	d _o (mm)	t _{fix, min} (mm)	t _{fix, max} (mm)	V _c (mm)	D _o (mm)	p _{min} (mm)	A/F (mm)	A/C (mm)	d ₂	
HBB-8/50	M8x50	50	9	9	24	19	25	20	13	15	18
HBB-10/60	M10x60	60	11	10	30	23	30	20	16	17	22
HBB-10/95	M10x95	95	11	25	65	23	30	20	16	17	22
HBB-10/130	M10x130	130	11	55	100	23	30	20	16	17	22
HBB-12/70	M12x70	70	13	12	35	26	35	25	18	20.5	26
HBB-12/120	M12x120	120	13	30	85	26	35	25	18	20.5	26
HBB-12/180	M12x180	180	13	80	140	26	5	25	18	20.5	26

Product Code Explanation:

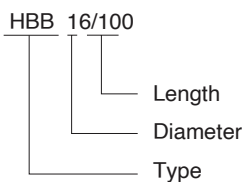

Application:

- Box Sections
- Vertical Cylindrical Sections
- Hollow Profiles
- Simple Connections

Available in:

Stainless Steel AISI 316 and Hot Deep Galvanized Mild Steel

10mm thickness base material class.

Load Direction	a degree	Allowable Loads (kN)		
		M8	M10	M12
Pull Out (Nrec)	0	6.9	12.9	18.8
Shear (Vrec)	90	14.6	23.2	33.7

A safety factor of 1.25 has been used against mean ultimate failure loads

Fixing Instructions

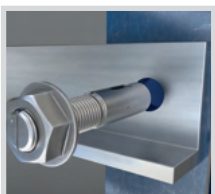

Drilling



Cleaning



Placing



Placing



Torque

HSDS-4 Concrete Screw - Technical Details

The HSDS-4 concrete screws, offer quick and easy installation without the need for extra tools or steps. They support high loads even with minimal spacing and edge distances, and their removability makes them ideal for temporary fixings.

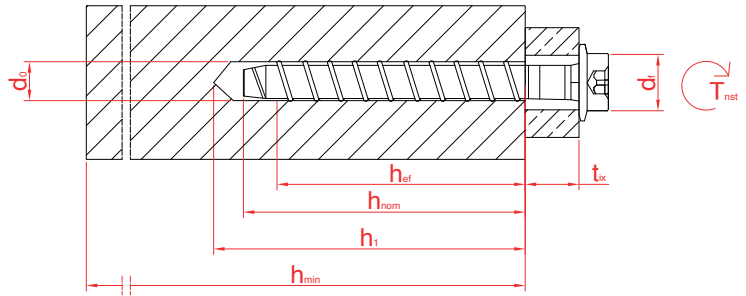
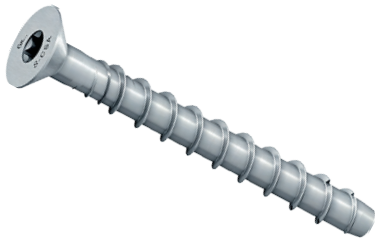

Product Code	Physical Features									
	Size	Length	Fixture Thickness	Embedment Depth	Nominal Diameter	Drill Hole Diameter	Eff. Anchorage Depth	Fixture Hole	Width Across Flats	Required Torque
	(mm)	L (mm)	t_{sk} (mm)	h_{nom} (mm)	h_1 (mm)	d_0 (mm)	h_{ef}	$d_1 \leq$	SW	T_{inst}
HSDS-4-6-50	M6x50	60	5	55	65	6	27.6	7.7-9.0	11 or 13	14
HSDS-4-6-80	M6x80	80	25	55	65	6	27.6	7.7-9.0	11 or 13	14
HSDS-4-6-100	M6x100	100	45	55	65	6	27.6	7.7-9.0	11 or 13	14
HSDS-4-6-120	M6x120	120	65	55	65	6	27.6	7.7-9.0	11 or 13	14

Product Code Example:

HSDS-4-8/110

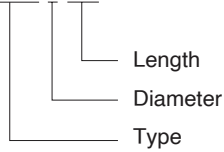

Application:

Facade scaffolds, temporary fastening, contact surfaces, shelves, cable racks, hand rails.

Available in:

Zinc-plated steel

10mm thickness base material class.

Allowable Loads (kN)		
Load Direction	a degree	M6
Pull Out (Nrec)	0	2.1
Shear (Vrec)	90	4.5

A safety factor of 1.25 has been used against mean ultimate failure loads

Fixing Instructions



Additional Bolts

Self Drill Screws

HSDS-1



Used for connecting profiled steel sheets to steel substructures between 1.5 mm and 4 mm thick.

Product Code	Physical Features	
	Length	Clamping Thickness
	(mm)	(mm)
HSDS-1-6-6.3x22	22	0 - 7
HSDS-1-6-6.3x25	25	0 - 10
HSDS-1-6-6.3x38	38	0 - 23

HSDS-2



- For fastening profiled steel sheets to steel substructures 4 mm to 10 mm thick
- For fastening profiled aluminum sheets or sandwich panels to steel substructures 4 mm to 10 mm thick

Product Code	Physical Features	
	Length	Clamping Thickness
	(mm)	(mm)
HSDS-2-12-5.5x40	40	0 - 11
HSDS-2-5.5x58	58	0 - 31
HSDS-2-5.5x118	118	65 - 91

- For fastening profiled aluminum sheets or sandwich panels to aluminum substructures 4 mm to 12 mm thick

HSDS-3



Used in roofing or cladding sheets to steel sections, aluminium sections and timber.

Product Code	Physical Features	
	Length	Clamping Thickness
	(mm)	(mm)
HSDS-3-6.5x75	75	0 - 25
HSDS-3-6.5x90	90	12 - 40
HSDS-3-6.5x115	115	37 - 65

DIN933

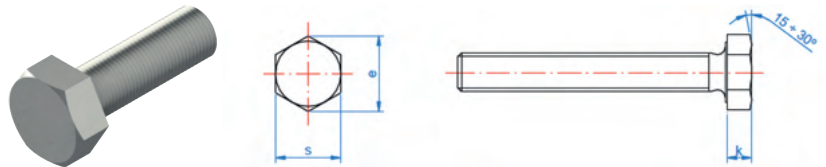

Product Code	Physical Features			
	Head Thickness	Distance Between Faces	Distance Between Apexes	Torque Wrench
	k (mm)	s (mm)	e (mm)	
DIN933-6	4	10	10.89	10
DIN933-8	5.3	13	14.20	13
DIN933-10	6.4	17	18.72	17
DIN933-12	7.5	19	20.88	19
DIN933-16	10	24	26.17	24

DIN934

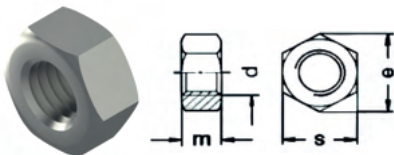

Product Code	Physical Features				
	Diameter	Thread Pitch	m	s	e
		(mm)	(mm)	(mm)	(mm)
DIN934-6	M6	1	4.7-5	9.78-10	11.05
DIN934-8	M8	1.25	6.14-6.5	12.73-13	14.38
DIN934-10	M10	1.5	7.64-8	16.73-17	18.9
DIN934-12	M12	1.75	9.64-10	18.67-19	21.1

DIN125

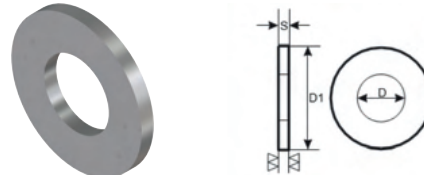

Product Code	Physical Features				
	Nominal Diameter	Inner Diameter	Outer Diameter	Thickness	Weight
		D (mm)	D1 (mm)	S (mm)	kg / 1000 pcs
DIN125-6	M6	6.4	12.5	1.6	1.14
DIN125-8	M8	8.4	17	1.6	2.14
DIN125-10	M10	10.5	21	2	4.08
DIN125-12	M12	13	24	2.5	6.27

Anchor Bolts Edge Reduction Factors - Standard Embedment

Edge Reduction Factors (Tension) Nrd

Bolt Size	Edge Distance (C1)								
	20	30	40	50	60	80	100	120	135
M6	0.27	0.48	0.56	0.78	1.00				
M8	0.35	0.48	0.60	0.79	0.98	1.00			
M10			0.39	0.55	0.70	0.83	1.00		
M12				0.48	0.59	0.80	0.98	1.00	
M16						0.60	0.80	0.90	1.00

Edge Reduction Factors (Shear) Vrd

Bolt Size	Edge Distance (C2)								
	20	30	40	50	60	80	100	120	135
M6	0.18	0.23	0.27	0.64	1.00				
M8	0.12	0.21	0.30	0.37	0.44	1.00			
M10			0.21	0.29	0.37	0.52	1.00		
M12					0.22	0.44	0.66	1.00	
M16						0.45	0.60	0.70	1.00

Spacing Reduction Factors (Tension) Nrd

Bolt Size	Spacing (S)								
	40	50	60	80	100	120	140	160	180
M6	0.61	0.72	0.82	1.00					
M8		0.65	0.70	0.75	1.00				
M10			0.65	0.77	0.88	0.91	1.00		
M12				0.65	0.75	0.82	0.88	1.00	
M16						0.70	0.80	0.85	1.00

Single anchor case

$$N_{rd.red} = C1 * N_{Rd}$$

$$V_{rd.red} = C2 * V_{Rd}$$

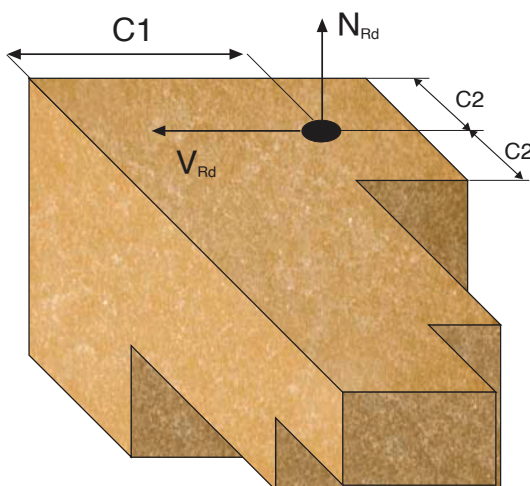

Double anchor case

$$N_{rd.red} = C1 * S * N_{Rd}$$

$$V_{rd.red} = C2 * S * V_{Rd}$$

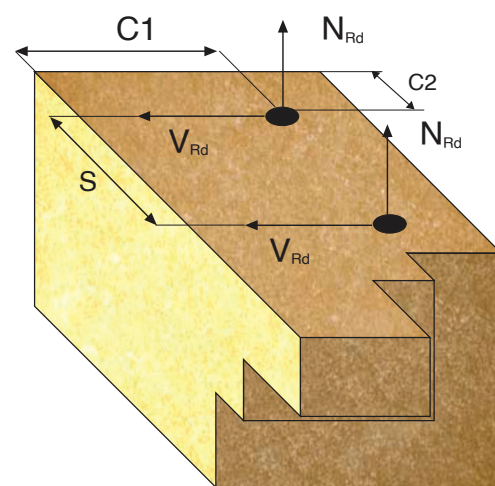

Nrd: Axial design resistance.

Vrd: Shear design resistance.

Expansion Bolts Reduction Factors - Reduced Embedment

Edge Reduction Factors (Tension) N_{rd}

Edge Distance (C1)								
Bolt Size	20	30	40	50	60	80	100	110
M6	0.58	0.75	0.88	1.00				
M8	0.42	0.66	0.89	0.95	1.00			
M10		0.53	0.59	0.65	0.77	1.00		
M12		0.38	0.46	0.53	0.62	0.81	1.00	
M16					0.45	0.60	0.80	1.00

Edge Reduction Factors (Shear) V_{rd}

Edge Distance (C2)								
Bolt Size	20	30	40	50	60	80	100	110
M6	0.16	0.32	0.66	1.00				
M8	0.13	0.26	0.38	0.69	1.00			
M10		0.16	0.29	0.41	0.61	1.00		
M12			0.13	0.24	0.35	0.68	1.00	
M16					0.30	0.55	0.70	1.00

Spacing Reduction Factors (Tension) N_{rd}

Spacing (S)									
Bolt Size	20	30	40	50	60	80	100	120	140
M6	0.56	0.58	0.60	0.80	1.00				
M8			0.65	0.71	0.77	1.00			
M10					0.65	0.77	1.00		
M12						0.65	0.67	1.00	
M16						0.50	0.80	0.70	1.00

Single anchor case

$$N_{rd.red} = C1 * N_{Rd}$$

$$V_{rd.red} = C2 * V_{Rd}$$

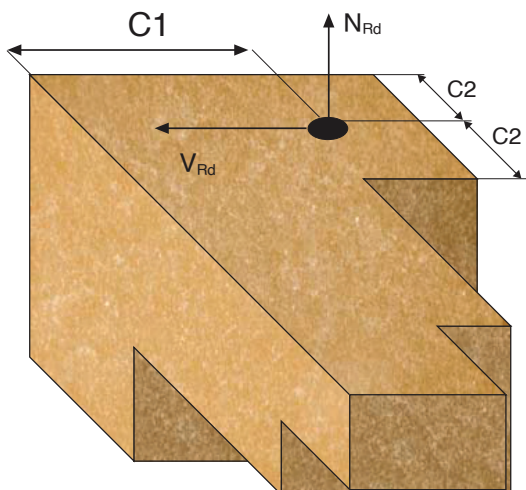

Double anchor case

$$N_{rd.red} = C1 * S * N_{Rd}$$

$$V_{rd.red} = C2 * S * V_{Rd}$$

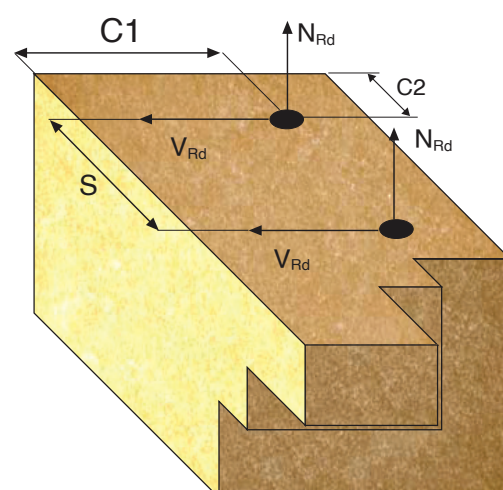

N_{rd} : Axial design resistance.
 V_{rd} : Shear design resistance.

Chemical Bolt Reduction Factors

Edge Reduction Factors - (Tension) N_{Rd}

Edge Distance C (mm)	Bolt Size				
	M8	M10	M12	M16	M20
40	0.70				
50	0.74	0.72			
60	0.78	0.75	0.71		
70	0.81	0.78	0.74	0.72	
80	0.85	0.82	0.77	0.74	
90	0.89	0.85	0.80	0.77	0.71
100	0.93	0.88	0.82	0.79	0.73
120	1.00	0.95	0.88	0.84	0.76
140		1.00	0.93	0.89	0.80
170			1.00	0.96	0.85
190				1.00	0.89
220					0.94
260					1.00

Single anchor case

$$N_{rd.red} = C1 * N_{Rd}$$

$$V_{rd.red} = C2 * V_{Rd}$$

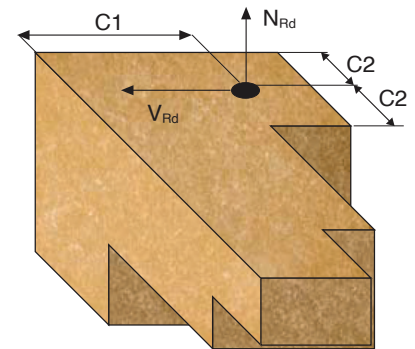

Edge Reduction Factors - (Shear) V_{Rd}

Edge Distance C (mm)	Bolt Size				
	M8	M10	M12	M16	M20
40	0.40				
50	0.50	0.44			
60	0.60	0.53	0.44		
70	0.70	0.62	0.51	0.45	
80	0.80	0.71	0.58	0.51	
90	0.90	0.80	0.65	0.58	0.42
100	1.00	0.89	0.73	0.64	0.47
120		1.00	0.87	0.77	0.56
140			1.00	0.90	0.66
170				1.00	0.80
190					0.89
220					1.00

Double anchor case

$$N_{rd.red} = C1 * S * N_{Rd}$$

$$V_{rd.red} = C2 * S * V_{Rd}$$

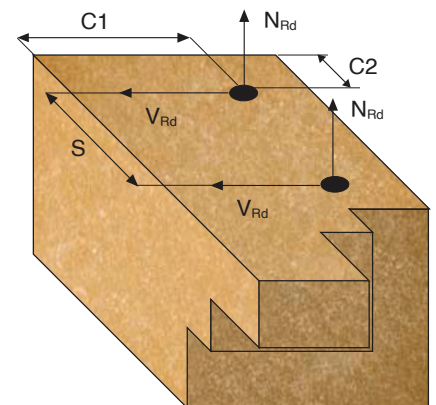

Spacing Reduction Factors - (Tension & Shear) N_{Rd} & V_{Rd}

Distance Between Anchors S (mm)	Bolt Size				
	M8	M10	M12	M16	M20
40	0.78				
50	0.83	0.80			
60	0.89	0.85	0.80		
70	0.94	0.90	0.84	0.80	
80	1.00	0.95	0.88	0.84	
90		1.00	0.92	0.87	
100			0.95	0.91	0.80
110			1.00	0.95	0.84
130				1.00	0.89
150					0.95
170					1.00

Embedment Reduction Factor = Actual Embedment Depth / Minimum Embedment

Eurocode Concept

Partial vs Global Safety

Factors

The new DIN 1045-1:2001-07 standard has created the bases of abandoning the Global Safety factors and is leading towards a common standard design concept in Europe.

The change from allowable loads to design resistance loads may cause confusion when selecting fixings.

When mistakes are made the choice of fixings are either 40 % over design making it uneconomical because the fixings selected are too big; or 40 % under design making it on safe because the loads applied are 40 % higher than assumed.

In order to prevent mistakes the applied loads and the resistance of fixings must be correctly determined and compared.

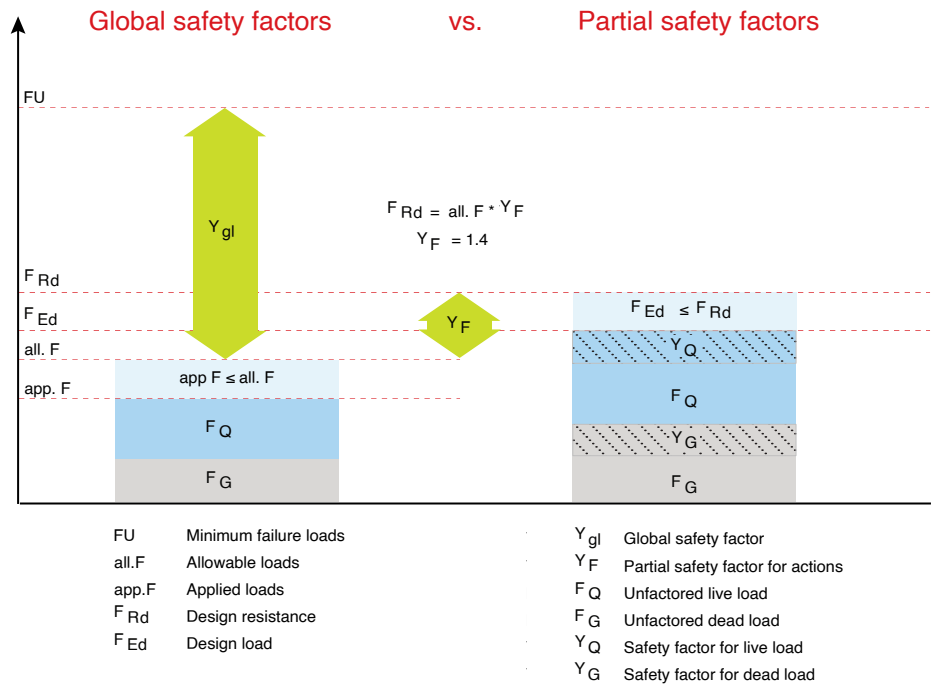

Global Safety Factors

With the current Global safety factor concept, the allowable loads (all. F) are determined for fixings. Applied characteristic force loads (app. F) are compared with the allowable loads. Allowable loads represent the nominal load capacity and is derived from test results which are then divided by global safety factor (Y_{gl}). The chosen fixing is considered safe with the following condition:

$$Applied\ loads\ (app.F) \leq Allowable\ loads\ (all.F)$$

Partial Safety Factors

The design verification according to Euro code 2 for concrete and Euro code 3 for steel is taken into consideration during the design level. The applied loads (app. F) are factored with partial factors: for static loads 1.35 and for dynamic loads 1.5. The applied design forces (F_{Ed}) are compared with the Design resistance loads (F_{Rd}). The design resistance is determined by dividing the characteristic resistance of the fixings with the partial material safety factors subsequently for concrete and steel. The chosen fixing is considered safe with the following condition:

$$Design\ Load\ (F_{Ed}) \leq Design\ Resistance\ (F_{Rd})$$

The new Euro code concept leads to achieving a more constant and reliable safety level by taking into account different influences of load and materials.

Allowable loads vs Design Resistance Loads

In order to design fixings according to the new Euro concept the, applied loads must be factored using partial safety factors to determined the design loads (F_{Ed}). The design loads must be compared with the design resistance (F_{Rd}) values of the products to be chosen. If the design resistance values are not available and only allowable loads are available, the new design resistance values must be calculated. The partial factor for actions here 1.4 is weighted average of partial load safety factors 1.35 for permanent loads and 1.5 for variable loads. The global safety factor remains safe with this equation.

$$Design\ Resistance\ (F_{Rd}) = allowable\ loads\ (all.F) \cdot 1.4$$

Loads indicated on this catalogue

The loads on this catalogue are the allowable loads already factored from the characteristics loads. The allowable loads are labelled as all. F.

$$Allowable\ loads\ (all.F)$$



Since its beginning in 1993, HAZ Metal has proved its reliability by successfully completing challenging projects. HAZ Metal has established a reputation for being a reliable supplier of structural components for facade construction.

Prestigious and large scale projects around the world have been supplied with high quality fixing systems designed and manufactured by HAZ Metal.

Always at the forefront of fixing technology, HAZ METAL has established a wide product portfolio to complement its fixing systems targeted for the specialist external wall cladding market. Designing and engineering high integrity and quality products for facade applications made HAZ a worldwide known brand in the construction industry.

HAZ METAL combines the very latest international technology with its own research and development team to establish a technical excellence within the industry. HAZ METAL readily embraces the responsibility of a major producer and shares its expertise with problem solving solutions.



HAZ Metal is certified with integrated management systems by TUV SUD for ISO 9001 & OHSAS 18001



HAZ
Group of Companies
Establishment
www.hazgrp.com
HAZ Metal A.S.
is a member of HAZ Group
of Companies

HAZ METAL UK LTD
154 Great North Road Hatfield
Herts. AL9 5JN England
Tel: +44 (0) 1707 - 260 180
www.hazmetal.co.uk
info@hazmetal.co.uk

HAZ METAL SANAYİ VE TİCARET A.Ş.
Şehit Er Çıracı Caddesi No. 10
Akçay Sanayi Bölgesi 31200 İskenderun
Hatay, TÜRKİYE
Tel : +90 (0) 326 626 20 50
Fax : +90 (0) 326 626 20 45
www.hazmetal.com
info@hazmetal.com

HAZ PAZARLAMA İÇ & DIŞ TIC. A.Ş.
İçerenköy Mh. Çayır Cd. Özce Center
No:3 K:12 34752 Ataşehir
İstanbul, TÜRKİYE
Tel: +90 (0) 216 410 72 06
info@hazgrp.com

HAZ METAL DEUTSCHLAND GmbH
Alfred-Zippe-Straße 1
97877 Wertheim, GERMANY
Tel: +49 (0) 9342 9359
www.hazmetal.eu
info@hazmetal.de